

# MJ03M CARPET TILE EDGE

MJ03M is designed to finish carpet tiles to a lower adjoining floor surface.

The 5mm cavity edge of MJ03M provides reinforced protection to the trimmed edge of carpet tiles or direct stick carpets

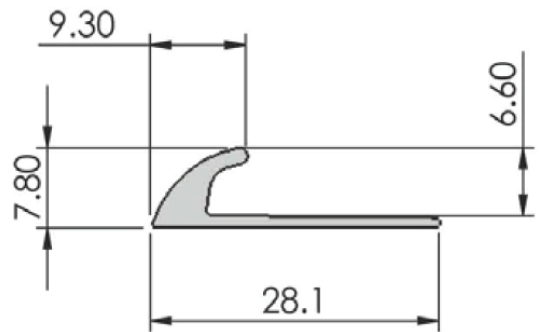
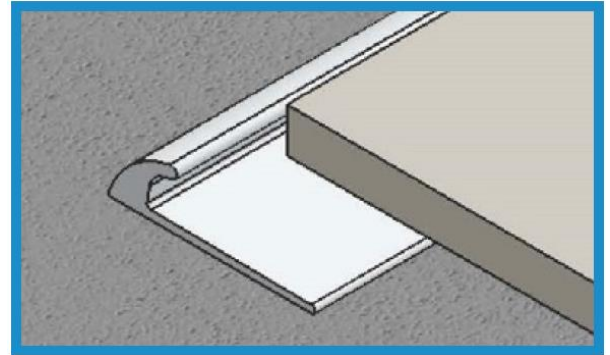

## Product specifications

Product code:	<b>MJ03M</b>
Overall length:	3.66m
Horizontal width:	28.1mm
Vertical Height:	7.8mm
Finish:	Mill Finish
Lengths per carton:	10

## Installation instructions

Cut the MJ03M to your required length. Secure in place using MJS GF400 adhesive. The MJ03M can also be drilled and counter-sunk for screw-fixing if required (screws and plugs sold separately). Once adhesive is cured install the carpet tile into the carpet tile edge.

**Safety statement:** When cutting or drilling aluminium we recommend the use of safety glasses and gloves.

